

BigBang C9 D9 R9

Standard geometries

FRAME SIZE VR		Front Typical Rider Height	Rear Typical Rider Height	Effective Top Tube Length	Effective Top Tube Length	Seat Tube Length to Top	Seat Tube Length to Top	Effective Chainstay length	Bottom Bracket Height	Head Tube Length	Maximum high	Fork rake	Head Tube Angle	Seat Tube Angle	Seat Tube Angle
cm	inch	[1]V-cm	[2]V-cm	[1]A1-mm	[2]A1-mm	[1]B2-mm	[2]B2-mm	C1-mm	D-mm	F-mm	I-mm	K-mm	a -°	[1]b -°	[2]b -°
C9 - CROSS COUNTRY SERIES															
44 / 38	17,3 / 15,0	164-171	151-155	578	686	440	380	424	290	125	525	45	70	73,5	73,5
46 / 40	18,1 / 15,7	172-176	156-166	586	712	460	400	424	290	135	537	45	70,5	73,5	73,5
48 / 44	18,9 / 17,3	177-181	167-171	594	712	480	440	424	290	135	537	45	70,5	73,5	73,5
50 / 46	19,7 / 18,1	182-186	172-176	602	738	500	460	424	290	145	546	45	70,5	73,5	73,5
52 / 46	20,5 / 18,1	187-191	172-176	610	738	520	460	424	290	155	556	45	70,5	73,5	73,5
54 / 48	21,3 / 18,9	192-196	177-181	618	738	540	480	424	290	165	565	45	70,5	73,5	73,5
D9 - MULTIROAD SERIES															
46 / 42	18,1 / 16,5	155-164	149-154	544	686	460	420	439	288	125	547	45	70	74	74
50 / 46	19,7 / 18,1	165-175	155-164	567	712	500	460	439	288	145	568	45	70,5	74	74
54 / 48	21,3 / 18,9	176-187	165-174	590	712	540	480	439	288	165	587	45	70,5	74	74
58 / 50	22,8 / 19,7	188-197	175-181	613	738	580	500	439	288	185	606	45	70,5	74	74
R9 - ROAD SERIES															
52 / 46	20,5 / 18,1	163-167	149-151	539	686	520	460	405	270	125	560	45	71,5	74	74
54 / 48	21,3 / 18,9	168-172	152-157	549	686	540	480	405	270	135	571	45	72	74	74
56 / 50	22,0 / 19,7	173-177	158-162	560	712	560	500	405	270	145	581	45	72	73,5	74
58 / 50	22,8 / 19,7	178-182	158-162	571	712	580	500	405	270	155	590	45	72	73,5	74
58 / 54	22,8 / 21,3	178-182	163-172	571	712	580	540	405	270	165	600	45	72	73,5	73,5
60 / 54	23,6 / 21,3	183-187	163-172	583	712	600	540	405	270	175	609	45	72	73	73,5
62 / 56	24,4 / 22,0	188-192	173-177	595	738	620	560	405	270	185	619	45	72	73	73,5

Geometre je platná pro rok 2008. Výrobce si vyhrazuje právo změny.

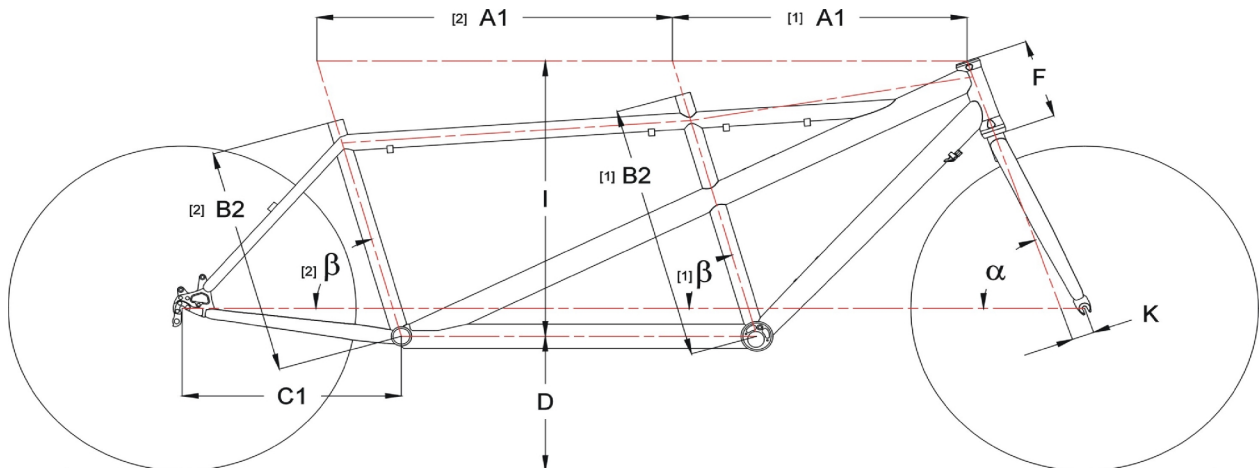

Customer's geometry

FRAME SIZE VR		Front Typical Rider Height	Rear Typical Rider Height	Effective Top Tube Length	Effective Top Tube Length	Seat Tube Length to Top	Seat Tube Length to Top	Effective Chainstay length	Bottom Bracket Height	Head Tube Length	Maximum high	Fork rake	Head Tube Angle	Seat Tube Angle	Seat Tube Angle
cm	inch	[1]V-cm	[2]V-cm	[1]A1-mm	[2]A1-mm	[1]B2-mm	[2]B2-mm	C1-mm	D-mm	F-mm	I-mm	K-mm	a -°	[1]b -°	[2]b -°