

# Career C14

## Standard geometries

FRAME SIZE VR		Typical Rider Height	Effective Top Tube Length	Seat Tube Length to Top	Effective Chainstay length	Bottom Bracket Height	Head Tube Length	Maximum high	Fork rake	Head Tube Angle	Seat Tube Angle
cm	inch	V-cm	A1-mm	B2-mm	C1-mm	D-mm	F-mm	I-mm	K-mm	a - °	b - °
36	14,2	149-150	538	360	424	292	115	557	44	70	74
38	15,0	151-155	550	380	424	292	115	557	44	70	74
40	15,7	156-161	561	400	424	292	115	557	44	70	74
42	16,5	162-166	575	420	424	292	115	559	44	70,5	73,5
44	17,3	167-171	586	440	424	292	125	568	44	70,5	73
46	18,1	172-176	595	460	424	292	135	577	44	70,5	73
48	18,9	177-181	608	480	424	292	135	577	44	70,5	73
50	19,7	182-186	620	500	424	292	145	587	44	70,5	73
52	20,5	187-191	633	520	424	292	155	596	44	70,5	73
54	21,3	192-196	645	540	424	292	165	606	44	70,5	73
56	22,0	197-201	658	560	424	292	185	625	44	70,5	73

Geometrie je platná pro rok 2008. Výrobce si vyhrazuje právo změny.

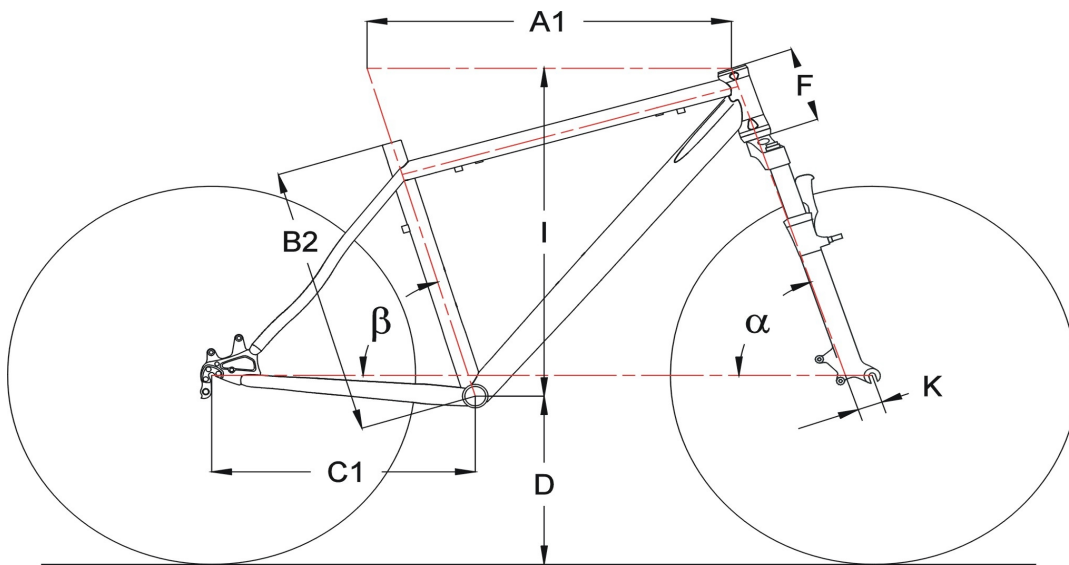

## Customer's geometry

FRAME SIZE VR		Typical Rider Height	Effective Top Tube Length	Seat Tube Length to Top	Effective Chainstay length	Bottom Bracket Height	Head Tube Length	Maximum high	Fork rake	Head Tube Angle	Seat Tube Angle
cm	inch	V-cm	A1-mm	B2-mm	C1-mm	D-mm	F-mm	I-mm	K-mm	a - °	b - °