

Cool R12

Standard geometries

FRAME SIZE VR		Typical Rider Height	Effective Top Tube Length	Seat Tube Length to Top	Effective Chainstay length	Bottom Bracket Height	Head Tube Length	Maximum high	Fork rake	Head Tube Angle	Seat Tube Angle
cm	inch	V-cm	A1-mm	B2-mm	C1-mm	D-mm	F-mm	I-mm	K-mm	a - °	b - °
48	18,9	155-157	521	480	399	268	105	504	43	71,5	75
49	19,3	158-160	525	490	399	268	105	506	43	72	75
50	19,7	161-162	529	500	399	268	105	506	43	72	74,7
51	20,1	163-165	534	510	399	268	105	506	43	72	74,5
52	20,5	166-167	539	520	399	268	115	517	43	72,5	74,4
53	20,9	168-170	544	530	399	268	125	526	43	72,5	74
54	21,3	171-172	549	540	399	268	135	537	43	73	74
55	21,7	173-175	555	550	400	270	145	545	43	73	73,5
56	22,0	176-177	560	560	400	270	155	555	43	73	73,5
57	22,4	178-180	566	570	400	270	165	564	43	73	73,5
58	22,8	181-182	571	580	400	270	175	574	43	73	73,5
59	23,2	183-185	577	590	400	270	185	585	43	73,5	73,5
60	23,6	186-187	583	600	401,5	270	195	595	43	73,5	73
61	24,0	188-190	589	610	401,5	270	205	604	43	73,5	73
62	24,4	191-192	595	620	401,5	270	215	614	43	73,5	73
63	24,8	193-195	601	630	401,5	270	225	623	43	73,5	73
64	25,2	196-198	607	640	401,5	270	235	633	43	73,5	73

Geometre je platná pro rok 2008. Výrobce si vyhrazuje právo změny.

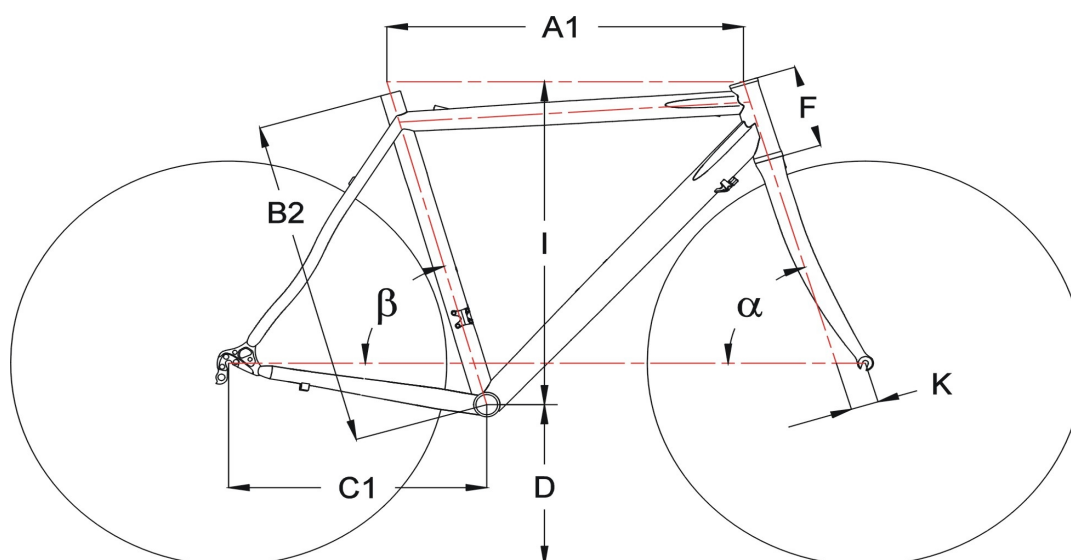

Customer's geometry

FRAME SIZE VR		Typical Rider Height	Effective Top Tube Length	Seat Tube Length to Top	Effective Chainstay length	Bottom Bracket Height	Head Tube Length	Maximum high	Fork rake	Head Tube Angle	Seat Tube Angle
cm	inch	V-cm	A1-mm	B2-mm	C1-mm	D-mm	F-mm	I-mm	K-mm	a - °	b - °