

Rebel 58

Standard geometries

FRAME SIZE VR		Typical Rider Height	Effective Top Tube Length	Seat Tube Length to Top	Effective Chainstay length	Bottom Bracket Height	Head Tube Length	Maximum high	Fork rake	Head Tube Angle	Seat Tube Angle
cm	inch	V-cm	A1-mm	B2-mm	C1-mm	D-mm	F-mm	I-mm	K-mm	a - °	b - °
50	19,7	161-162	530	500	421	290	105	517	50	71,5	74,5
51	20,1	163-165	535	510	421	290	105	519	50	72	74,5
52	20,5	166-167	540	520	421	290	115	529	50	72	74
53	20,9	168-170	545	530	421	290	125	540	50	72,5	74
54	21,3	171-172	550	540	421	290	135	549	50	72,5	73,5
55	21,7	173-175	555	550	421	290	145	559	50	72,5	73,5
56	22,0	176-177	565	560	421	290	155	570	50	73	73,5
57	22,4	178-180	575	570	421	290	165	580	50	73	73
58	22,8	181-182	585	580	421	290	175	589	50	73	73
59	23,2	183-185	595	590	421	290	185	599	50	73	73
60	23,6	186-187	600	600	421	290	195	609	50	73	73
61	24,0	188-190	605	610	421	290	205	618	50	73	73
62	24,4	191-192	610	620	421	290	215	628	50	73	73

Geometrie je platná pro rok 2008. Výrobce si vyhrazuje právo změny.

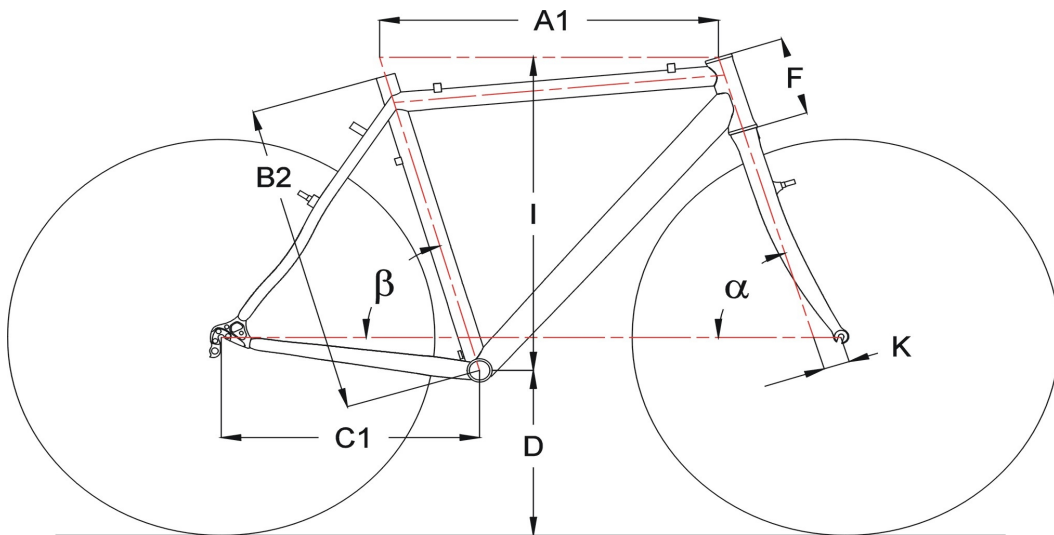

Customer's geometry

FRAME SIZE VR		Typical Rider Height	Effective Top Tube Length	Seat Tube Length to Top	Effective Chainstay length	Bottom Bracket Height	Head Tube Length	Maximum high	Fork rake	Head Tube Angle	Seat Tube Angle
cm	inch	V-cm	A1-mm	B2-mm	C1-mm	D-mm	F-mm	I-mm	K-mm	a - °	b - °