

# Sendic FX

## Standard geometries

FRAME SIZE VR		Typical Rider Height	Effective Top Tube Length	Seat Tube Length to Top	Effective Chainstay length	Bottom Bracket Height	Head Tube Length	Maximum high	Fork rake	Head Tube Angle	Seat Tube Angle
cm	inch	V-cm	A1-mm	B2-mm	C1-mm	D-mm	F-mm	I-mm	K-mm	a - °	b - °
44	17,3	167-171	588	440	424	310	125	548	44	70	73,5
46	18,1	172-176	599	460	424	310	135	557	44	70	73,5
48	18,9	177-181	611	480	424	310	135	557	44	70	73,5
50	19,7	182-186	623	500	424	310	145	567	44	70	73,5
52	20,5	187-191	636	520	424	310	155	576	44	70	73,5
54	21,3	192-196	648	540	424	310	165	586	44	70	73,5

Geometre je platná pro rok 2008. Výrobce si vyhrazuje právo změny.

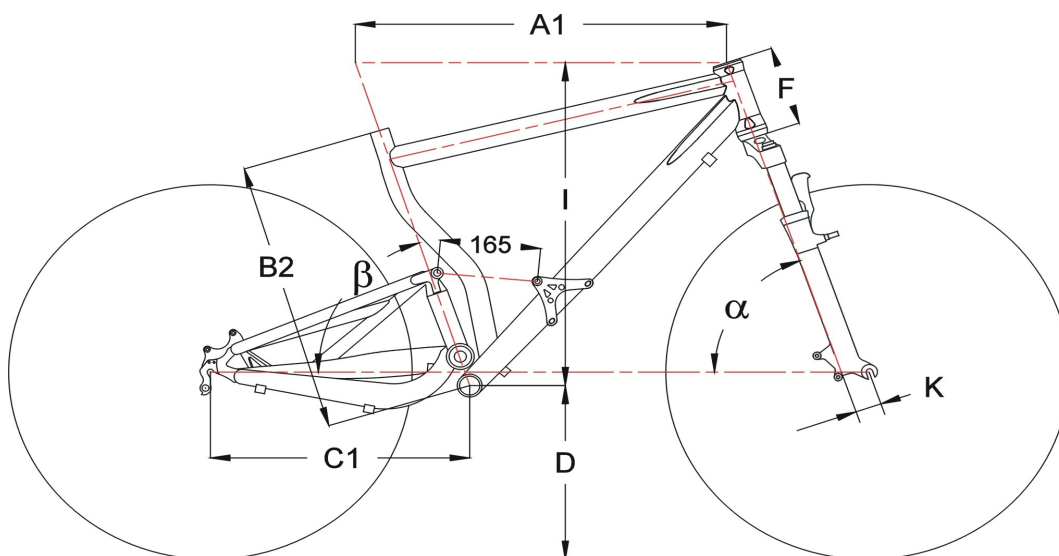

## Customer's geometry

FRAME SIZE VR		Typical Rider Height	Effective Top Tube Length	Seat Tube Length to Top	Effective Chainstay length	Bottom Bracket Height	Head Tube Length	Maximum high	Fork rake	Head Tube Angle	Seat Tube Angle
cm	inch	V-cm	A1-mm	B2-mm	C1-mm	D-mm	F-mm	I-mm	K-mm	a - °	b - °