

Sprinter T11

Standard geometries

| FRAME SIZE VR | | Typical Rider Height | Effective Top Tube Length | Seat Tube Length to Top | Effective Chainstay length | Bottom Bracket Height | Head Tube Length | Maximum high | Fork rake | Head Tube Angle | Seat Tube Angle |
|---------------|------|----------------------|---------------------------|-------------------------|----------------------------|-----------------------|------------------|--------------|-----------|-----------------|-----------------|
| cm | inch | V-cm | A1-mm | B2-mm | C1-mm | D-mm | F-mm | I-mm | K-mm | a - ° | b - ° |
| 52 | 20,5 | 166-167 | 534 | 470 | 386 | 282 | 95 | 485 | 43 | 73 | 75 |
| 53 | 20,9 | 168-170 | 539 | 470 | 386 | 282 | 95 | 485 | 43 | 73 | 75 |
| 54 | 21,3 | 171-172 | 545 | 480 | 386 | 282 | 105 | 495 | 43 | 73 | 74,7 |
| 55 | 21,7 | 173-175 | 550 | 490 | 386 | 282 | 105 | 496 | 43 | 73,5 | 74,7 |
| 56 | 22,0 | 176-177 | 555 | 500 | 386 | 282 | 115 | 506 | 43 | 73,5 | 74,5 |
| 57 | 22,4 | 178-180 | 561 | 510 | 386 | 282 | 125 | 515 | 43 | 73,5 | 74,5 |
| 58 | 22,8 | 181-182 | 566 | 520 | 386 | 282 | 135 | 525 | 43 | 73,5 | 74,5 |
| 59 | 23,2 | 183-185 | 571 | 530 | 386 | 282 | 145 | 535 | 43 | 73,5 | 74,5 |
| 60 | 23,6 | 186-187 | 577 | 540 | 386 | 282 | 155 | 544 | 43 | 73,5 | 74,5 |
| 61 | 24,0 | 188-190 | 583 | 550 | 386 | 282 | 165 | 554 | 43 | 73,5 | 74,5 |
| 62 | 24,4 | 191-192 | 589 | 560 | 386 | 282 | 175 | 563 | 43 | 73,5 | 74 |
| 63 | 24,8 | 193-195 | 595 | 570 | 386 | 282 | 185 | 573 | 43 | 73,5 | 74 |
| 64 | 25,2 | 196-198 | 601 | 580 | 386 | 282 | 195 | 583 | 43 | 73,5 | 74 |

Geometre je platná pro rok 2008. Výrobce si vyhrazuje právo změny.

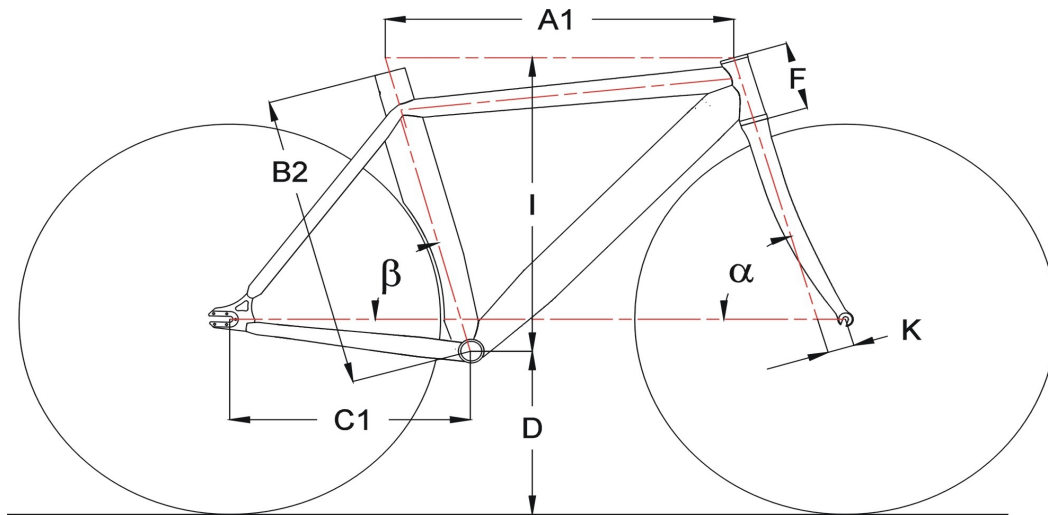

Customer's geometry

| FRAME SIZE VR | | Typical Rider Height | Effective Top Tube Length | Seat Tube Length to Top | Effective Chainstay length | Bottom Bracket Height | Head Tube Length | Maximum high | Fork rake | Head Tube Angle | Seat Tube Angle |
|---------------|------|----------------------|---------------------------|-------------------------|----------------------------|-----------------------|------------------|--------------|-----------|-----------------|-----------------|
| cm | inch | V-cm | A1-mm | B2-mm | C1-mm | D-mm | F-mm | I-mm | K-mm | a - ° | b - ° |
| | | | | | | | | | | | |
| | | | | | | | | | | | |