

Trophy D10

Standard geometries

FRAME SIZE VR		Typical Rider Height	Effective Top Tube Length	Seat Tube Length to Top	Effective Chainstay length	Bottom Bracket Height	Head Tube Length	Maximum high	Fork rake	Head Tube Angle	Seat Tube Angle
cm	inch	V-cm	A1-mm	B2-mm	C1-mm	D-mm	F-mm	I-mm	K-mm	a - °	b - °
pevná vidlice hard fork											
42	16,5	149-154	529	420	441	288	135	552	50	70	74
46	18,1	155-164	544	460	441	288	155	573	50	70,5	74
50	19,7	165-175	559	500	441	288	175	594	50	71	74
54	21,3	176-187	574	540	441	288	195	613	50	71	74
58	22,8	188-197	589	580	441	288	215	632	50	71	74
62	24,4	198-202	604	620	441	288	235	651	50	71	74
odpružená vidlice suspension fork											
42	16,5	149-154	529	420	441	288	115	580	50	70	74
46	18,1	155-164	544	460	441	288	125	592	50	70,5	74
50	19,7	165-175	559	500	441	288	135	603	50	71	74
54	21,3	176-187	574	540	441	288	145	613	50	71	74
58	22,8	188-197	589	580	441	288	165	632	50	71	74
62	24,4	198-202	604	620	441	288	185	651	50	71	74

Geometrie je platná pro rok 2008. Výrobce si vyhrazuje právo změny.

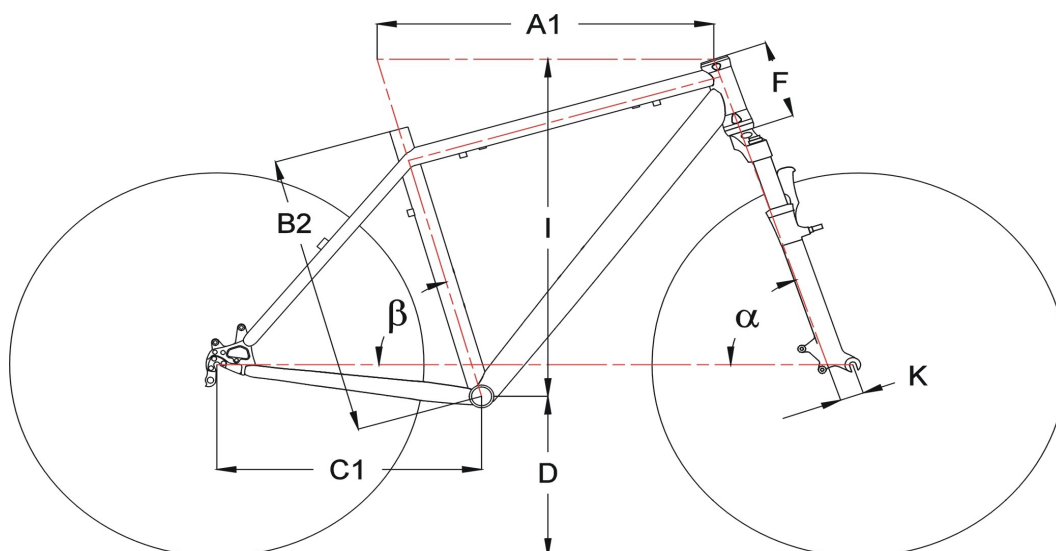

Customer's geometry

FRAME SIZE VR		Typical Rider Height	Effective Top Tube Length	Seat Tube Length to Top	Effective Chainstay length	Bottom Bracket Height	Head Tube Length	Maximum high	Fork rake	Head Tube Angle	Seat Tube Angle
cm	inch	V-cm	A1-mm	B2-mm	C1-mm	D-mm	F-mm	I-mm	K-mm	a - °	b - °